

sway strut

model : SSA
SSB
C-SSA

sway strut assembly : model SSA
corrosion resistant : C-SSA
field alterable strut : model SSB



SERVICE : Used to restrain movement of piping in one direction while providing for movement due to thermal expansion or contraction in another direction.

HOW TO SIZE :

1. Select size consistent with max. load to be restrained.
2. Determine distance from structural steel to center of pipe and subtract from it, pipe clamp take out (dim. E) for pipe size being restrained and rear bracket (dim. A) for size selected. This will give required C to C dimension. Check to be within limits of min. and max. C-C dimension listed for size selected.
3. Determine W dimension by subtracting (2 times dimension F) from C-C dimension.

INSTALLATION : Shipped assembled. Securely fasten bracket to structure, make necessary adjustment in overall length and fasten clamp to pipe.

FEATURES :

- Effective under either tensile or compressive force.
- Provides 90mm (model SSA) or 50mm (model SSB) of field adjustment in either direction.
- Self-aligning bushings permit $\pm 5^\circ$ misalignment or angular motion. Bushings are coated with a dry lubricant.

ORDERING : Specify model name, assembly size, option number if other than standard configuration is required or nominal pipe size or special O.D, and "W" dimension. Alloy pipe clamps are available as a special order. The rear bracket assembly may be ordered separately.

For restraint parallel to the pipe axis using two sway strut assemblies, a riser clamp is available. If a riser clamp is required, consult with **Unison** for information about this clamp.

E-TAKE OUT

pipe size	M20 rod end size	M24 rod end size	M30 & M36 rod end size	M42 & M48 rod end size	M56 rod end size	M64 rod end size	M80 rod end size	M100 rod end size
	size A	size B & C	size 1 & 2	size 3 & 4	size 5	size 6	size 7	size 8
20A(3/4B)	60	180	-	-	-	-	-	-
25A(1B)	65	180	-	-	-	-	-	-
32A(1 1/2B)	70	180	-	-	-	-	-	-
40A(1 1/2B)	105	180	-	-	-	-	-	-
50A(2B)	130	180	180	205	255	-	-	-
65A(2 1/2B)	135	180	180	205	255	-	-	-
80A(3B)	150	180	180	205	255	-	-	-
90A(3 1/2B)	155	180	180	205	255	-	-	-
100A(4B)	165	185	185	215	255	-	-	-
125A(5B)	195	195	195	230	255	-	-	-
150A(6B)	215	215	215	255	255	300	-	-
200A(8B)	240	240	240	285	285	320	-	-
250A(10B)	265	265	265	325	325	360	360	415
300A(12B)	-	300	300	350	350	390	390	440
350A(14B)	-	320	320	370	370	405	415	455
400A(16B)	-	345	345	385	385	435	445	485
450A(18B)	-	370	370	415	415	465	470	515
500A(20B)	-	400	400	450	450	490	500	545
600A(24B)	-	460	460	505	505	550	550	610
750A(30B)	-	540	540	585	585	635	635	710
900A(36B)	-	610	610	675	675	715	715	795

sway strut

model : SSA

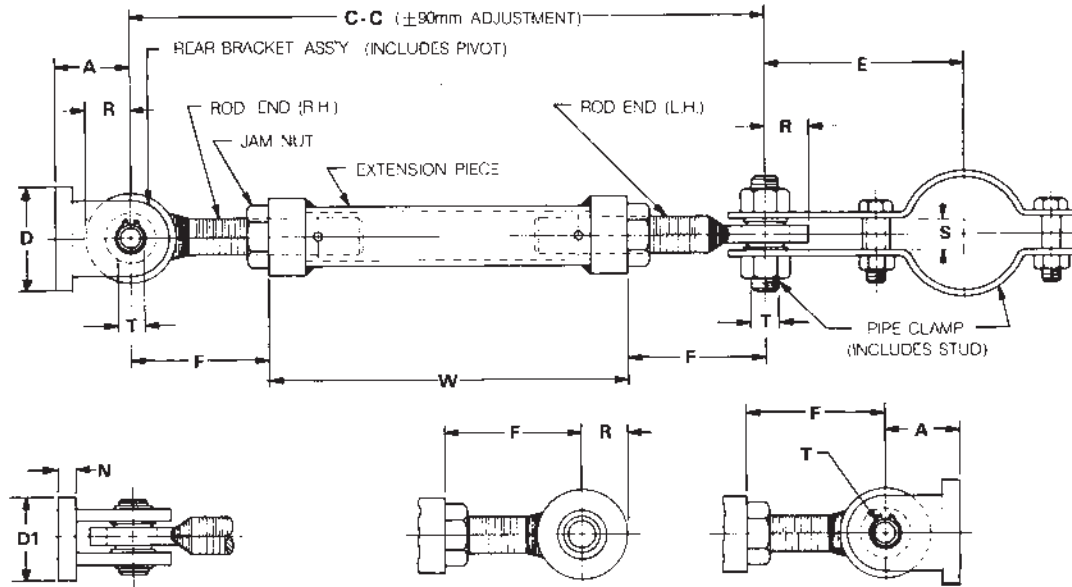

OPTION 1

OPTION 2

loads • dimensions (mm)

size	load [■] kg	rod end	extension piece	A	C-C		W		F	D	D ₁	N	R	S	T _{nom.}
					max	min	max	min							
A	295	M 20	25A(1B)	25	1525	425	1335	235	95	73	38	6	15	15	10
B	680	M 24	40A(1½B)	55	2745	500	2495	250	125	127	92	12	35	35	20
C	2040	M 24	50A(2B)	55	3055	500	2805	250	125	127	92	12	35	35	20
1	3630	M 30	50A(2B)	65	3050	540	2790	280	130	114	77	19	40	35	25
2	5275	M 36	65A(2½B)	65	3050	560	2770	280	140	114	77	19	40	35	25
3	7120	M 42	65A(2½B)	85	3050	610	2720	280	165	137	90	24	50	45	30
4	9390	M 48	80A(3B)	85	3050	675	2700	325	175	137	90	24	50	45	30
5	12340	M 56	80A(3B)	100	3050	715	2660	325	195	155	108	32	65	50	40
6	15195	M 64	100A(4B)	125	3050	765	2610	325	220	200	137	45	75	60	45
7	30935	M 80	100A(4B)	145	3050	885	2540	375	255	232	160	50	90	75	50
8	54430	M100	150A(6B)	185	3050	1080	2400	430	325	355	222	60	120	90	60

■ Loads must not be applied outside a 10° included angle cone of action to the pipe clamp axis without special authorization.

sway strut

model : SSB

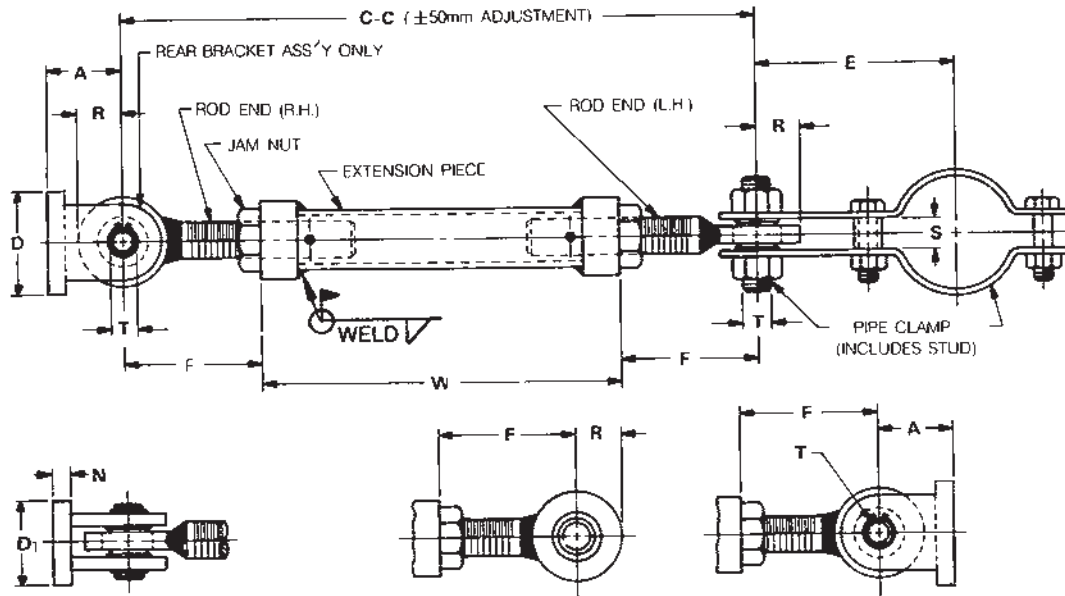

OPTION 1

OPTION 2

loads • dimensions (mm)

size	load [■] kg	rod end	extension piece	A	C-C		F	D	D ₁	N	R	S	T _{nom.}	Weld
					max	min								
A	295	M 20	25A(1B)	25	1525	335	75	73	38	6	15	15	10	5
B	680	M 24	40A(1½B)	55	2440	415	110	127	92	12	35	35	20	5
C	2040	M 24	50A(2B)	55	2440	415	110	127	92	12	35	35	20	5
1	3630	M 30	50A(2B)	65	2440	460	115	114	77	19	40	35	25	8
2	5275	M 36	65A(2½B)	65	2440	475	120	114	77	19	40	35	25	8
3	7120	M 42	65A(2½B)	85	2440	520	145	137	90	24	50	45	30	8
4	9390	M 48	80A(3B)	85	2440	580	155	137	90	24	50	45	30	10
5	12340	M 56	80A(3B)	100	2440	620	180	155	108	32	65	50	40	10
6	15195	M 64	100A(4B)	125	2440	665	200	200	137	45	75	60	45	10
7	30935	M 80	100A(4B)	145	2440	785	235	232	160	50	90	75	50	16
8	54430	M100	150A(6B)	185	2440	985	305	355	222	60	120	90	60	19

■ Loads must not be applied outside a 10° included angle cone of action to the pipe clamp axis without special authorization.

mini-sway strut assembly

model : SSC

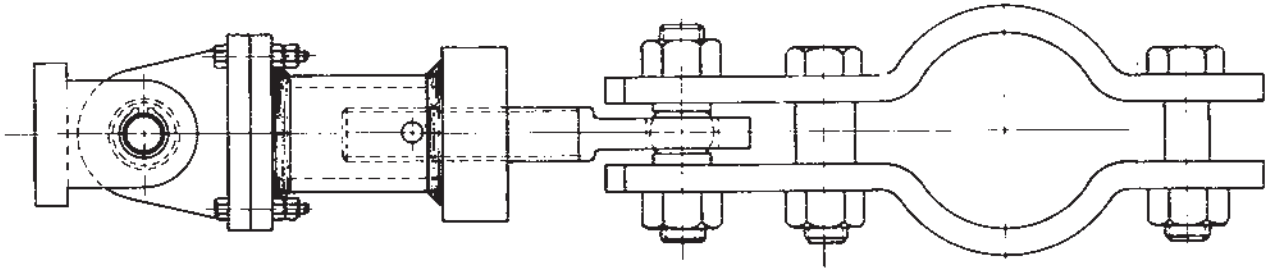

(see next page for dimensions)

E - TAKE OUT

pipe size	M20 rod end size	M24 rod end size	M30 & M36 rod end size
	size A	size B & C	size 1 & 2
20A(3/4B)	60	180	-
25A(1B)	65	180	-
32A(1 1/2B)	70	180	-
40A(1 1/2B)	105	180	-
50A(2B)	130	180	180
65A(2 1/2B)	135	180	180
80A(3B)	150	180	180
90A(3 1/2B)	155	180	180
100A(4B)	165	185	185
125A(5B)	195	195	195
150A(6B)	215	215	215
200A(8B)	240	240	240
250A(10B)	265	265	265
300A(12B)	-	300	300
350A(14B)	-	320	320
400A(16B)	-	345	345
450A(18B)	-	370	370
500A(20B)	-	400	400
600A(24B)	-	460	460
750A(30B)	-	540	540
900A(36B)	-	610	610

MAXIMUM RECOMMENDED LOAD : 3630 Kg

SERVICE : Used to restrain movement of piping in one direction while providing for movement due to thermal expansion or contraction in another direction.

HOW TO SIZE :

1. Select size consistent with max. load to be restrained.
2. Determine distance from structural steel to center of pipe and subtract from it, pipe clamp take out (dim. E) for pipe size being restrained and rear bracket (dim. A) for size selected. This will give required C to C dimension. Check to be within limits of min. and max. C-C dimension listed for size selected.

INSTALLATION : Shipped assembled. Securely fasten bracket to structure, make necessary adjustment in overall length, and fasten clamp to pipe.

FEATURES :

- Assembly provides a shorter C to C dimension.
- Effective under either tensile or compressive force.
- Self-aligning bushings permit ±5° misalignment or angular motion. Bushings are coated with a dry lubricant.

ORDERING : Specify assembly size no, model name, pipe O.D. or option no. if other than standard, and load. Alloy pipe clamps are available as a special order.
ex) SSC-A-2, 273mm O.D pipe, C-C=185mm

For restraint parallel to the pipe axis using two sway strut assemblies, a riser clamp is available. If a riser clamp is required, consult with **UNISON** for information about this clamp.

mini-sway strut assembly

model : SSC

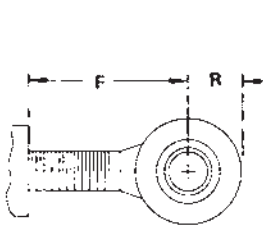
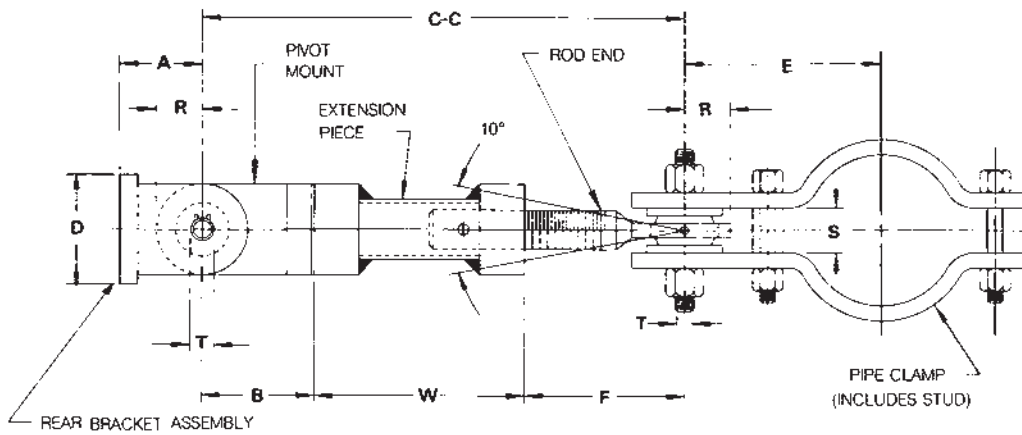

OPTION 1

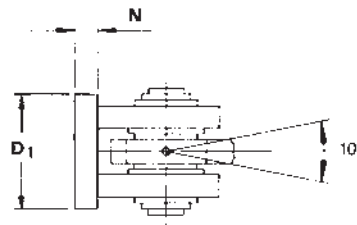

dimensions(mm)

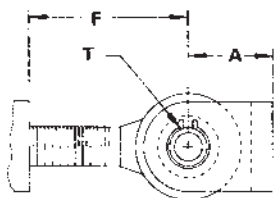

OPTION 2

assembly size no.	C-C		F		W	
	max	min	max	min		
A	A-1	165	135	70	40	65
	A-2	220	165	110	55	80
	A-3	340	220	160	40	150
B & C	C-1	170	155	75	60	40
	C-2	200	170	90	60	55
	C-3	220	195	95	70	70
	C-4	280	225	125	70	100
	C-5	395	280	185	70	155
	C-6	500	395	235	130	210
1	1-1	230	205	95	70	55
	1-2	270	225	115	70	75
	1-3	300	260	120	80	100
	1-4	390	305	165	80	145
	1-5	550	385	245	80	225

size	rod end	A	D	D ₁	N	R	S	T nom.	B
A	M20	25	73	32	6	15	15	10	30
B	M24	55	127	92	12	35	35	20	55
C	M24	55	127	92	12	35	35	20	55
1	M30	65	115	75	19	40	35	25	80

On these sizes the extension piece consists of round bar stock that is drilled and tapped. Loads must not be applied outside a 10° included angle cone of action to the pipe clamp axis without special authorization.

NOTE : The rear bracket assembly may be ordered separately.